

HIGH SIDE & LOW SIDE FLOAT CONTROL For Ammonia (R-717) and Halocarbon Refrigerants

Features

- **Pressure Rating: 300PSI (-20°F – +240°F)**
- **ASTM A536 Gr. 65-45-12 Ductile Iron Body**
- **Efficiently Transfers Oil from Oil Separators to Compressor Crankcase**
- **Simple Needle and Seat Construction**
- **Cast Ductile Iron or Steel Chamber**
- **External or Internal Mounting**

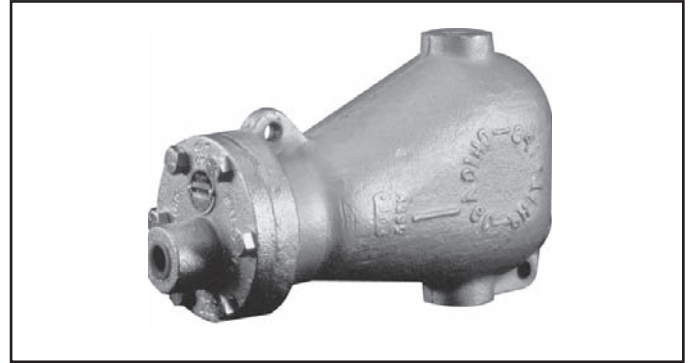

Design Function – 270A High Side Float Valve

The Phillips® 270A High Side Float Valve, opening on a rise in level, will transfer oil from a discharge line oil separator to the crankcase of the compressor or to an oil reservoir. This valve is used for oil in ammonia (R-717) and halocarbon systems. The standard orifice supplied in the valve is 3/32" and will operate to a pressure drop of 250 PSI maximum. The capacity of the valve with oil, when fitted with the standard 3/32" orifice, is approximately 1-1/2 GPM at 100 PSI pressure drop. The valve is of all steel construction with a simple needle and seat, and is available with or without chamber. The standard chamber is of ductile iron, and various types of welding flanges are available for internally mounting the float valve in a vessel.

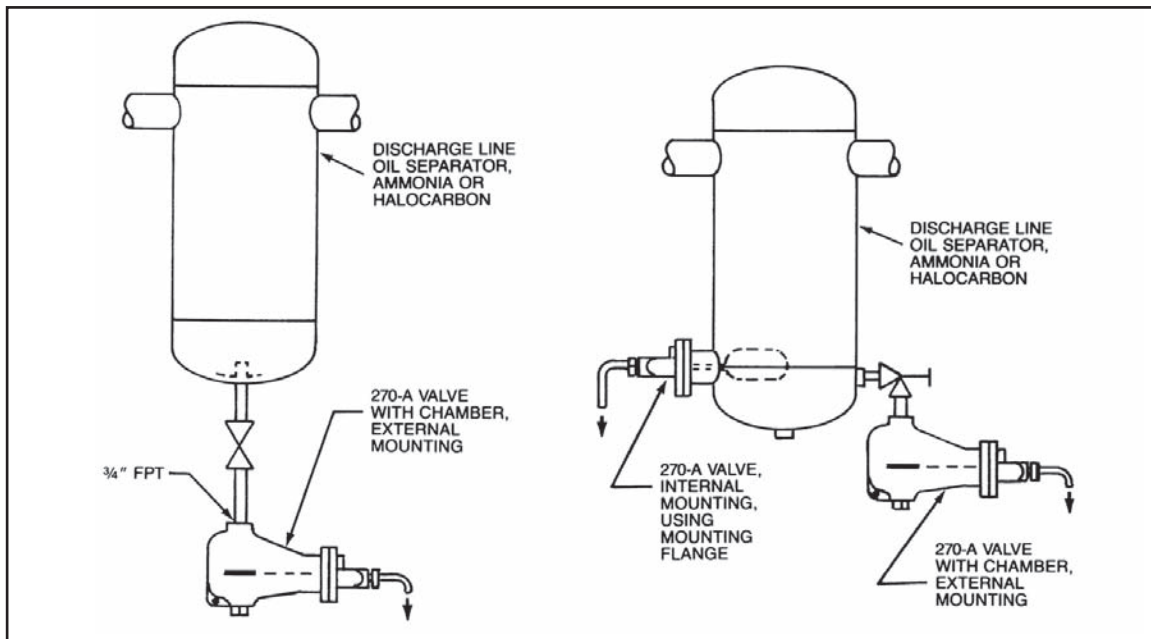

Application of 270A High Side Oil Drain Valve. Various Methods of Installation Shown

OIL DRAIN VALVE

VALVE NO.	ORIFICE	SHIPPING WT. (LBS.)	
		VALVE ONLY	VALVE WITH CAST CHAMBER
270A	3/32"	8	22

MOUNTING FLANGES

FLANGE NO.	TYPE OF FLANGE	THICKNESS	WELD TO:		SHIPPING WT. (LBS.)
			PIPE	LENGTH	
298A	SOCKET WELD	0.50"	2-1/2" S/40	2-1/2"	2
250WF4	BUTT WELD	1.13"	4" S/40	2-1/2"	4

Design Function – 275AF Low Side Float Valve

The Phillips® 275AF Low Side Float Valve can be used to maintain the oil level in the crankcase of a compressor. For multiple compressor applications, a 275AF valve should be installed on each compressor. In this case, feed would be from an oil reservoir at an equal or greater pressure than the compressor crankcase. If the oil reservoir is at a pressure equal to the compressor crankcase, it must be elevated at least two feet above the desired compressor crankcase oil level so that gravity feed can take place. When the oil reservoir is at a greater pressure than the crankcase, it may be mounted low. Consult the table below for maximum orifice that can be used with various reservoir pressures.

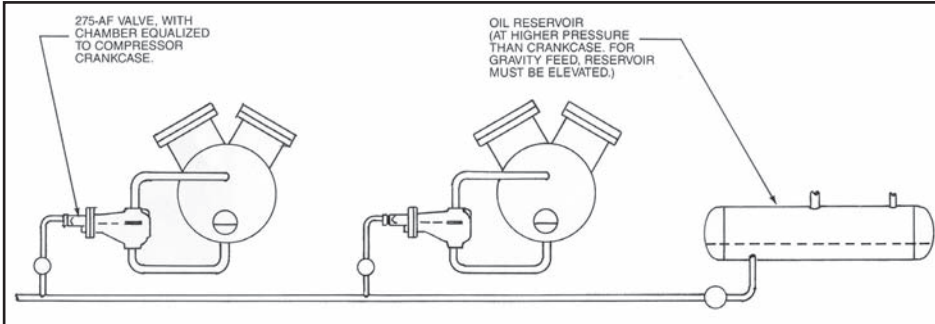

Application of 275AF Low Side Float Valve to Maintain Oil Level in Compressor Crankcase, Feeding From an Oil Reservoir.

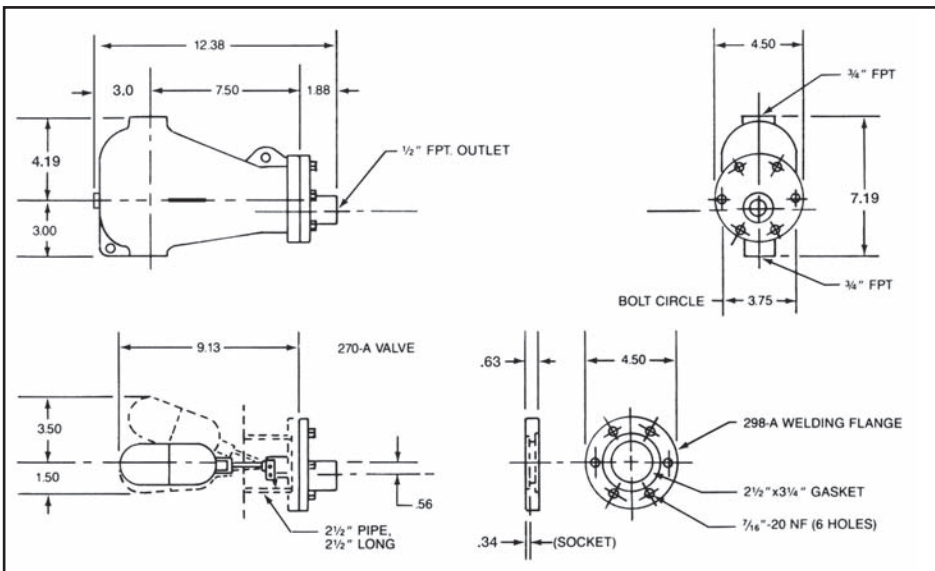

Series 270A High Side Valve, Cast Chamber, and Mounting Flange Dimensions

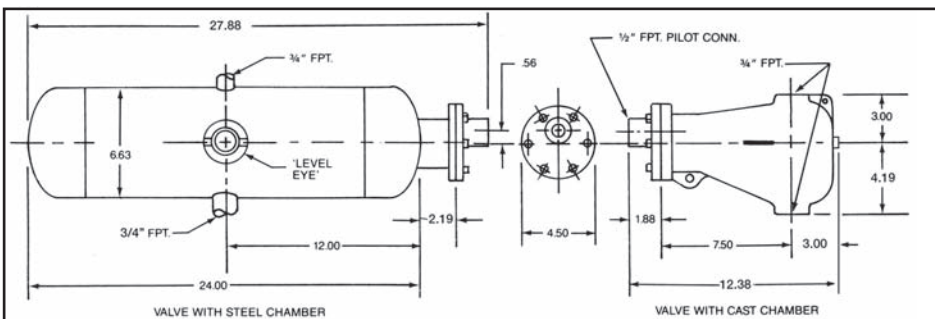

275AF Low Side Feed Valve with Steel Chamber Dimensions

OIL FEED VALVE

VALVE NO.	ORIFICE	SHIPPING WT. (LBS.)	
		VALVE ONLY	VALVE WITH CAST CHAMBER
275AF	SEE TABLE BELOW	8	22

275AF OIL VALVE CAPACITIES

ORIFICE (IN.)	Cv	GPM OIL		
		1 FT. HEAD	10 PSI DROP	20 PSI DROP*
1/16	.095	.06	.3	.42
5/64	.140	.08	.4	-
3/32	.170	.10	-	-
1/8	.380	.22	-	-
3/16	.700	.40	-	-

* Do not use the 275AF valve for pressure drops greater than 20 PSI. When higher pressure drops are encountered, consult PHILLIPS regarding the use of other types of low side valves that can be utilized.

ORDERING INSTRUCTIONS

Specify:

HIGH SIDE VALVE:

- (1) 270A Valve, 3/32" with cast chamber
OR
- (2) 270A Valve, 3/32" with steel chamber
OR
- (3) 270A Valve, 3/32" less chamber
- (4) Flange Number, if required

LOW SIDE VALVE:

- (1) Valve Number
- (2) Orifice
- (3) With cast chamber, steel chamber,
or less chamber
- (4) Flange Number, if required

H. A. Phillips & Co.

1612 Louise Drive
South Elgin, IL 60177-2242 U.S.A.
Phone: (630) 377-0050 • Fax: (630) 377-2706
E-mail: info@haphillips.com
or visit us @ www.haphillips.com

