

MODULATING LIQUID LEVEL CONTROL For Ammonia (R-717) and Halocarbon Refrigerants

- **Pressure Rating: 300PSI (-20°F – +240°F)**
- **ASTM A536 Gr. 65-45-12 Ductile Iron Body**

Design Function

The Phillips® Series 301E external mounting fixed level float valves are modulating liquid level controls, designed primarily for use with ammonia (R-717). The welded steel chamber has a Phillips® Level Eye® for a visual check of the liquid level. The valves incorporate a replaceable cartridge that contains the working needle and seat. Pump down of the chamber is required to service the valve. A typical application is shown to the right for reference. These valves are for use with unitary surge drums and evaporators, for intercooler or desuperheater level control, small ammonia or halocarbon chillers, or other applications requiring an external level control. A remote feed line is required from the valve outlet to the vessel or evaporator. When used in halocarbon systems, these valves are equipped with heavier float balls.

When greater capacities are required, these valves can be used as pilot float valves in conjunction with Phillips® Series 701 Pilot Operated valves. See Bulletin 701S for engineering data.

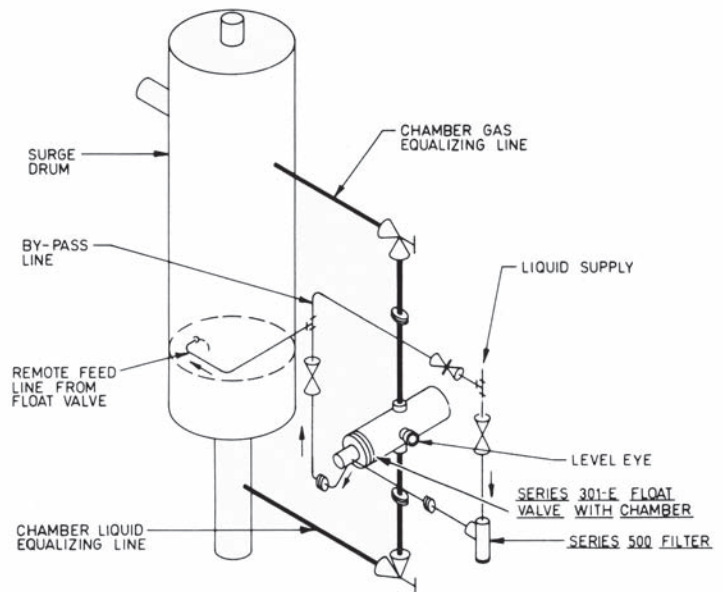

VALVE CAPACITIES – TONS*

VALVE NO.**	ORIFICE (IN.)	Cv	AMMONIA (R-717)					R-22				
			INLET PRESSURE (PSIG)					INLET PRESSURE (PSIG)				
			80†	100	125	160	200	80†	100	125	160	200
301E	5/64	.056	2.8	3.0	3.3	3.6	4.1	.65	.70	.80	.85	.90
	3/32	.11	5.5	6.0	6.6	7.3	8.2	1.3	1.4	1.6	1.7	1.8
	7/64	.18	9.0	9.7	11	12	13	2.2	2.3	2.5	2.8	3.0
	1/8	.26	13	14	16	17	19	3.2	3.4	3.7	4.0	4.3
	9/64	.31	15	17	19	21	23	3.8	4.0	4.4	4.7	5.1
301G	5/32	.40	18	20	22	25	28	4.0	4.2	5.0	5.5	5.9
	3/16	.43	22	23	26	29	32	5.3	5.5	6.0	6.5	7.1
301J##	3/16	.56	28	30	34	37	42	6.9	7.2	7.9	8.6	9.1
	7/32	.80	40	43	49	53	60	9.8	10	11	12	13
	9/32†	.97	48	52	-	-	-	12	12	14	15	16
301K	9/32	.97	48	52	59	66	74	12	12	14	15	16

* Calculated for operation with saturated liquid at the valve inlet. To develop these capacities, the pressure drop across the valve must be greater than one-half the inlet absolute pressure. When liquid is subcooled, valve capacity will increase. To calculate increase, see Liquid Sub-Cooling Factor table.

** Add suffix 'F' when ordering a valve for use with a halocarbon refrigerant.

The 3/16" and 7/32" orifices shown for the 301J valve can be used in the 301K valve at the indicated ratings.

† Limited to maximum pressure drop of 120 PSI with R-717.

‡ Valve capacities at 20 to 25 PSIG inlet pressures are 50% of these ratings. Outlet pressure must be 0 PSIG or less.

LIQUID SUB-COOLING FACTOR

°F of Sub-Cooling	5	10	20	30	50
Factor	1.25	1.47	1.75	1.9	2.2

Consult H. A. Phillips & Co. if special applications, other refrigerants, or unusual liquid conditions prevail.

Series 301E – Low Side Float Valves

Installation and Operation

The steel chamber for the valve should be installed with gas and liquid equalizing line hand service valves. Any servicing of the float valve, including change of cartridge, requires pump down of the chamber. On ammonia installations, do not trap the lower balance line as oil may be trapped. This will give a false liquid level indication, resulting in a higher level in the vessel than indicated by the Phillips® Level Eye®. If the lower equalizing line must be looped, an oil pot should be installed at the lowest point and periodically drained. Liquid supply is into the valve body from the right or left side. The remote feed exits from the front of the valve at 45 degrees, and the line must be piped to the surge drum or the evaporator. A liquid line filter is recommended. A bypass hand expansion valve is useful during servicing of the valve to maintain liquid level.

When the refrigeration load is greatly reduced on an individual air unit, or if fans are shut off, it is advisable to utilize a liquid line solenoid valve ahead of the float valve in order to stop liquid feed. Otherwise the body of liquid in the surge drum will flow down into the coil and the float valve will continue feeding, thus filling the coil with liquid refrigerant. Room thermostats can be utilized to stop liquid feed to the evaporators.

SERIES 301E VALVES – DATA

VALVE NUMBER	DIMENSIONS (IN.)						SHIPPING WT. WITH CHAMBER (LBS.)	SHIPPING WT. VALVE ONLY (LBS.)
	A	B	C	D	E	F		
301E	1/2	1/2	14	7.5	7.25	5.56	39	15
301G	1/2	3/4	14	7.5	7.25	5.56	40	16
301J	3/4	3/4	14	7.5	7.25	5.56	40	16
301K	3/4	3/4	18	9.5	8.38	6.63	55	22

SERIES 301E VALVE & STEEL CHAMBER DIMENSIONS

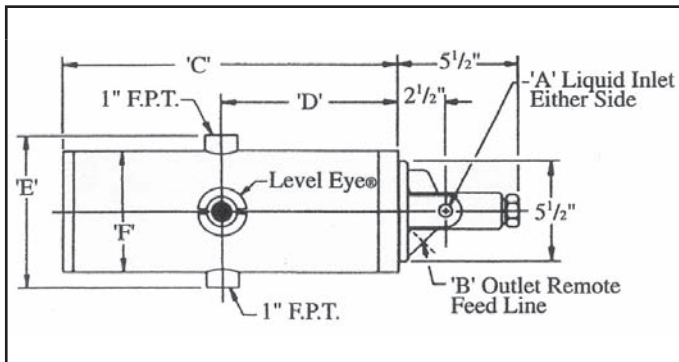

510



575

ORDERING INSTRUCTIONS

Specify:

- (1) Valve Number
- (2) Orifice Size
- (3) Chamber—With or Without
- (4) Filter—With or Without

ANGLE FILTERS

FILTER NO.	CONNECTIONS F.P.T.	USE WITH VALVES	SHIPPING WEIGHT (LBS.)
510-1/2	1/2"	301E, 301G	7
575-3/4	3/4"	301J, 301K	18

H. A. Phillips & Co.

1612 Louise Drive
 South Elgin, IL 60177-2242 U.S.A.
 Phone: (630) 377-0050 • Fax: (630) 377-2706
 E-mail: info@haphillips.com
 or visit us @ www.haphillips.com

