

PILOT OPERATED FLOAT VALVE & DIRECT ACTING FLOAT VALVE

Size: 1/2" - 3"

For Ammonia (R717) and Halocarbon Refrigerants

Features

- Pressure Rating: 300PSI (-20°F – +240°F)
- ASTM A536 Gr. 65-45-12 Ductile Iron Body and Bonnet
- Modulating Level
- Replaceable PTFE Seat Disc
- Manual Lifting Stem
- Seal Cap

Description

The Phillips Series 700H valves are pilot operated by a 275AP pilot float valve that modulates the flow of liquid refrigerant. These valves may also be applied to controlled pressure receivers, thermo syphon vessels, economizers, and for drainage of condensed vapor in heat reclaim vessels. These flanged piston type valves have a manual lifting stem and replaceable PTFE seat disc.

It is necessary to size the internal metering plug and spring for the design criteria to which the 700H valve is to be applied, including mass flow and pressure drop available across the valve. The valve is pilot operated by a remote pilot float valve with a pilot orifice suitably sized for each 700H body size.

Design Function

The typical application of the Series 700H Pilot Operated Valve is to maintain a liquid seal in the condenser drain line, or in a thermo-syphon vessel, utilizing a 275AP Pilot Float Valve in a chamber. The pilot float valve follows the liquid level.

As the condensing load increases, the 275AP float ball rises, slowly closing the pilot orifice. This reduces the pressure in the pilot line to the 700H valve, and pressure on top of the piston bleeds to the downstream side of the 700H valve. The balance of forces causes the piston with metering plug to rise, allowing more liquid to move downstream. Alternately, as the condensing load decreases, the float ball drops and opens the pilot orifice, thereby putting higher pressure on the power piston. The 700H valve then modulates toward reduced flow.

It is imperative to install a pressure gauge in the pilot line between the bonnet of the 700H valve and the 1/4" nominal pipe size hand valve.

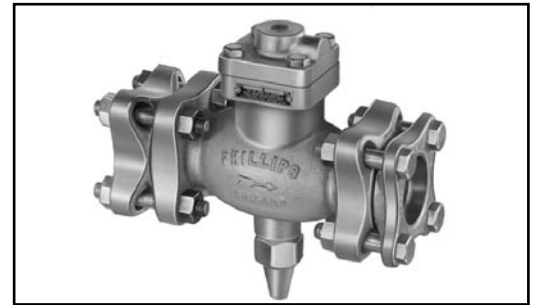

High Side Pilot Operated Valve-Series 700H

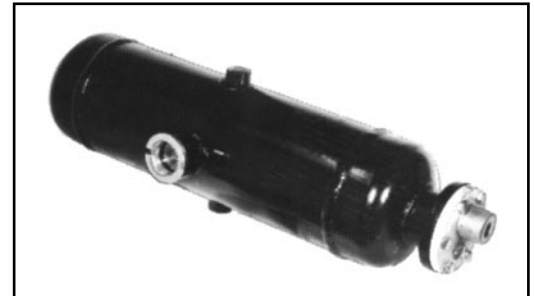

275AP Pilot Float Valve with Steel Chamber

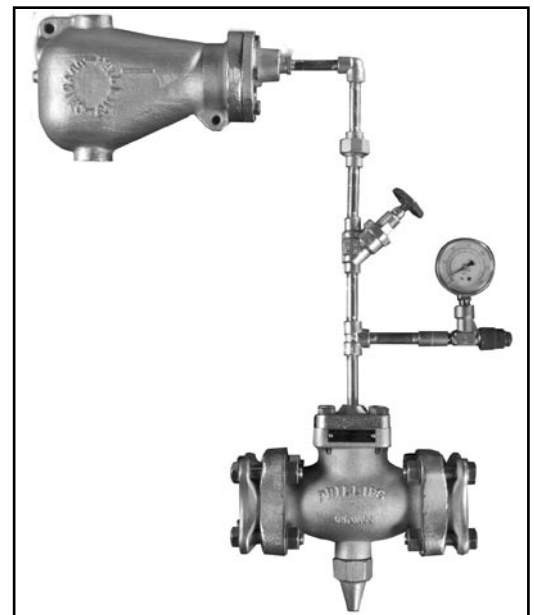

275AP Pilot Float Valve with Cast Chamber piped to 700H Valve

Schematic for Typical 700H Application

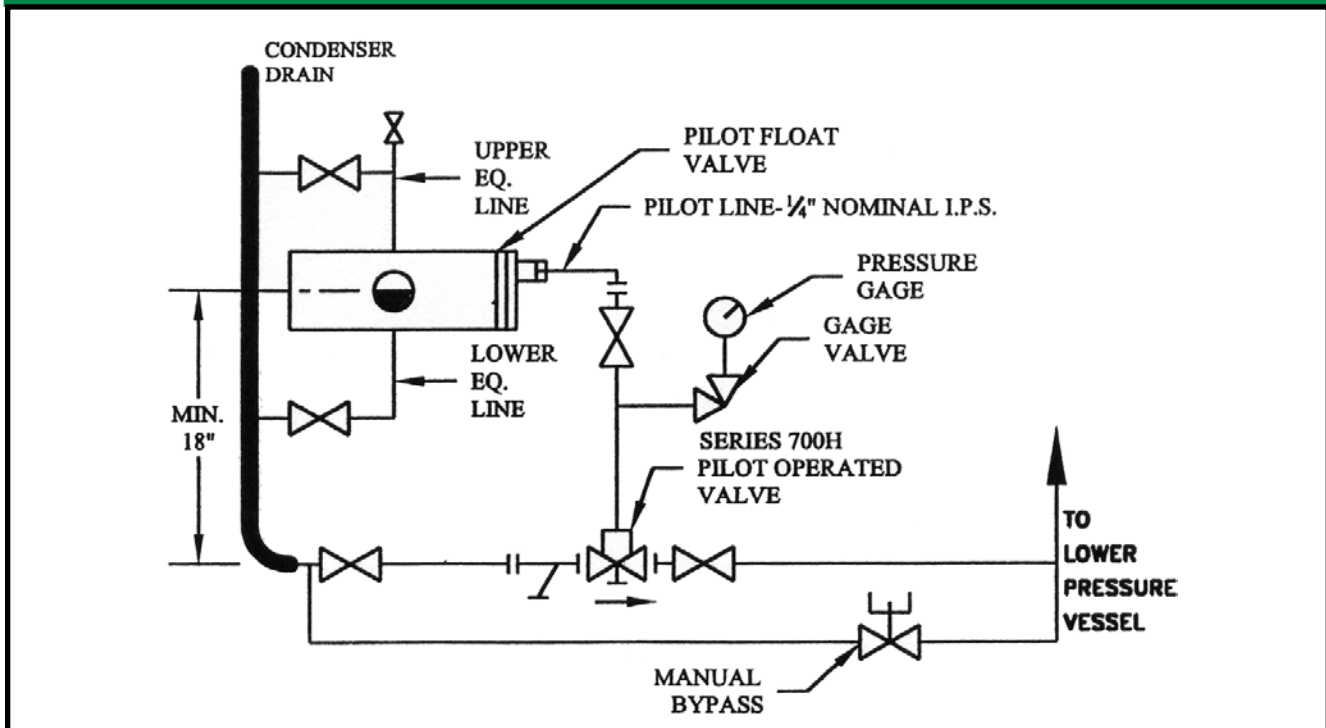

Valve Capacities- Tons

SERIES 700H VALVE CAPACITIES – TONS*

Table #1

| Valve No.*** | Cv | Metering Plug | Ammonia (R-717) | | | | | | R-22 | | | | |
|--------------|------|---------------|----------------------|------|------|------|------|------|----------------------|-----|-----|-----|-----|
| | | | Inlet Pressure--PSIG | | | | | | Inlet Pressure--PSIG | | | | |
| | | | 60 | 80** | 100 | 135 | 160 | 200 | 80** | 100 | 125 | 160 | 200 |
| 700JRH | 0.71 | 0 | 32 | 39 | 40 | 48 | 50 | 55 | 10 | 10 | 10 | 11 | 12 |
| | 1.04 | 1 | 47 | 57 | 60 | 70 | 75 | 82 | 14 | 15 | 15 | 16 | 18 |
| | 1.57 | 3 | 70 | 86 | 90 | 105 | 115 | -- | 21 | 22 | 23 | 24 | -- |
| 700XH | 0.78 | 0 | 35 | 42 | 45 | 53 | 55 | 60 | -- | -- | -- | -- | -- |
| | 1.68 | 2 | 75 | 90 | 97 | 114 | 118 | 129 | 23 | 24 | 24 | 26 | 29 |
| | 2.8 | 5 | 125 | 150 | 163 | 190 | 204 | 220 | 38 | 39 | 40 | 43 | 49 |
| | 4.0 | 8 | 180 | 205 | 235 | 270 | 290 | -- | 55 | 56 | 58 | 61 | 70 |
| | 4.7 | 10 | 210 | 255 | 274 | -- | -- | -- | 65 | 66 | 68 | 72 | -- |
| 700AXH | 2.87 | 0 | 129 | 158 | 168 | 197 | 210 | 230 | 39 | 40 | 41 | 44 | 49 |
| | 5.91 | 5 | 265 | 325 | 345 | 405 | 430 | 465 | 81 | 83 | 85 | 90 | 100 |
| | 11.2 | 10 | 500 | 615 | 655 | 765 | 815 | 880 | 155 | 157 | 160 | 170 | 195 |
| | 14.5 | 15 | 650 | 795 | 845 | 990 | -- | -- | 200 | 205 | 210 | 220 | 250 |
| | 18.9 | 20 | 850 | 1030 | -- | -- | -- | -- | 260 | 265 | 270 | 290 | -- |
| 700BXH | 4.04 | 0 | 180 | 220 | 235 | 275 | 295 | 320 | 55 | 56 | 58 | 62 | 70 |
| | 15.1 | 5 | 680 | 825 | 880 | 1030 | 1100 | 1190 | 205 | 210 | 215 | 230 | 260 |
| | 21.9 | 10 | 985 | 1200 | 1280 | 1500 | 1600 | 1730 | 300 | 305 | 315 | 335 | 380 |
| | 28.2 | 15 | 1250 | 1550 | 1650 | 1930 | 2050 | 2220 | 390 | 395 | 405 | 430 | 490 |
| | 35.0 | 20 | 1575 | 1920 | 2050 | 2390 | -- | -- | 480 | 490 | 505 | 535 | -- |
| | 39.6 | 25 | 1780 | 2170 | -- | -- | -- | -- | 545 | 555 | 570 | -- | -- |

* Calculated for operation with saturated liquid at the valve inlet. To develop these capacities, the pressure drop across the valve must be greater than one-half the inlet Absolute pressure. When liquid is subcooled, valve capacity will increase.

** Valve capacities at 20 to 25 PSIG inlet pressures are approximately 50% of the 80 PSIG ratings

*** Add suffix 'F' when ordering a valve for use with halocarbon refrigerant.

When ordering - Specify:
 Valve & Pilot Valve Numbers.
 Indicate if strainer required.
 Degrees of subcooling, if any.
 Minimum inlet pressure and pressure drop.

SERIES 700H VALVE SPRING SELECTION

| Valve No. | SPRING NUMBER (Number in brackets is the minimum required pressure drop across the pilot operated valve.*) | | | | |
|-----------|--|---------------|---------------|---------------|----------------|
| 700JRH | 705-IL (5) | 705-5L (20) | 705-10L (44) | 705-20L (70) | -- |
| 700XH | 705-IL (5) | 705-5L (16) | 705-10L (30) | 705-20L (60) | -- |
| 700AXH | 705-A2L (5) | 705-A10L (30) | 705-A30L (40) | 705-A60L (80) | -- |
| 700BXH | 705-B3L (5) | 705-B10L (16) | 705-B30L (30) | 705-B60L (44) | 705-B100L (80) |

* When the MINIMUM pressure drop available across the required series 700H valve falls between two successive numbers shown in brackets, choose the spring for the lower pressure drop.

Flash Tank Application

When the Series 700H valves are used in applications where a flash tank or controlled pressure receiver is involved, a correction factor must be made to the valve capacities shown in the table. This accounts for the typically lower pressure drops available across the pilot valve.

The table to the right indicate multipliers to be used at various upstream pressures.

| Flash Tank Pressure (PSIG) | Multipliers for Table #1 Capacities | | | | |
|----------------------------|-------------------------------------|-----|-----|-----|-----|
| | Upstream Pressure (PSIG) | | | | |
| | 80 | 100 | 135 | 160 | 200 |
| 45 | .83 | .95 | 1.0 | -- | -- |
| 60 | .80 | .85 | .90 | .96 | 1.0 |
| 70 | -- | .82 | .88 | .92 | 1.0 |
| 85 | -- | -- | .85 | .86 | .94 |
| 110 | -- | -- | .70 | .80 | .85 |

SERIES 700H PILOT OPERATED VALVES & 275AP PILOT VALVE DATA & CORRELATION

| Pilot Operated Valve* | Strainer | 275AP Pilot Float Valve* Orifice (In.) | Available Connections (inches) | | | Shipping Weights (Lbs.) | | | |
|-----------------------|----------|--|--------------------------------|-----------|--------------|-------------------------|-----------------------|--|---|
| | | | I.P.S.; Thd. Or Socket | Weld Neck | O.D. Copper | Pilot Oper. Valve | P.O. Valve w/Strainer | P.O. Valve Str., Float, & Cast Chamber | P.O. Valve Str., Float, & Steel Chamber |
| 700JRH | S701JR | 1/16 | 1/2, 3/4 | 1/2, 3/4 | 1-1/8, 1-3/8 | 16 | 25 | 47 | 75 |
| 700XH | S701 | 1/16 | 1, 1-1/4 | 1, 1-1/4 | 1-5/8 | 20 | 30 | 52 | 80 |
| 700AXH | S701A | 5/64 | 1-1/2, 2 | 1-1/2, 2 | 2-1/8 | 40 | 70 | 92 | 120 |
| 700BXH | S701B | 3/32 | 3 | 3 | 3-1/8 | 78 | 154 | 172 | 200 |

* Suffix 'F' on a valve number indicates its use with a halocarbon refrigerant.

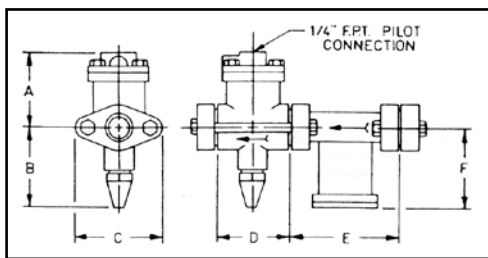

SERIES 700H VALVE DIMENSIONS (INCHES)

| Series 700H Valve | Flange Type | A | B | C | D | E | F |
|-------------------|-------------|------|------|------|-------|-------|-------|
| 700JRH | Oval | 4.19 | 4.50 | 4.13 | 3.50 | 5.88 | 4.50 |
| 700XH | Oval | 4.19 | 4.50 | 5.00 | 4.00 | 6.13 | 4.50 |
| 700AXH | Square | 5.38 | 5.25 | 4.75 | 8.75 | 9.75 | 7.75 |
| 700BXH | Square | 6.88 | 6.88 | 6.00 | 10.00 | 12.25 | 10.00 |

R22 NOMINAL CAPACITY MULTIPLIERS

| | |
|-------|------|
| R134A | 0.85 |
| R404A | 0.74 |
| R407A | 1.00 |
| R410A | 0.70 |
| R502 | 0.68 |
| R507 | 0.82 |

When ordering, specify: Valve & Pilot Valve; Chamber; Refrigerant and Capacity required. Indicate if strainer required. Advise inlet and outlet pressures.

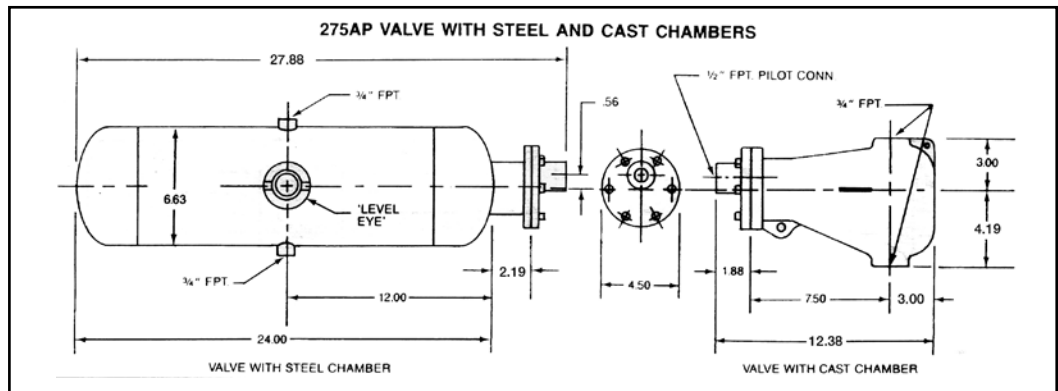

Series 270A Valves – Direct Feed

The Series 270A valves are direct feed High Side level controls. Mounted in a chamber balanced to a vessel, or directly in a sump, a rise in level will open the orifice and allow liquid to flow downstream.

These valves are simple needle and seat construction. The 270A valve has a single port, but the 270AX and 270AY valves are balanced port valves, allowing their use with larger orifices and at greater pressure drops across the valve.

These valves are generally applied to refrigeration systems with a fixed charge, but are also applicable as liquid drainers for condensate forming in hot gas defrost supply lines, or to drain heat reclaim exchangers.

Series 270A Valve with Cast Chamber



SERIES 270A VALVE CAPACITIES – TONS*

| Valve No. *** | Cv | Orifice (In.) | Ammonia (R-717) | | | | | | R-22 | | | | |
|---------------|------|---------------|-----------------------|------|-----|-----|-----|-----|-----------------------|-----|-----|-----|-----|
| | | | Inlet Pressure – PSIG | | | | | | Inlet Pressure – PSIG | | | | |
| | | | 60 | 80** | 100 | 135 | 160 | 200 | 80** | 100 | 135 | 160 | 200 |
| 270A | 0.10 | 1/16 | 4.2 | 5.0 | 5.4 | 6.3 | 6.7 | 7.5 | 1.2 | 1.3 | 1.4 | 1.5 | 1.6 |
| | 0.14 | 5/64 | 6.2 | 7.4 | 8.0 | 9.4 | 10 | 11 | 1.8 | 1.9 | 2.1 | 2.2 | 2.4 |
| | 0.17 | 3/32 | 7.5 | 9.0 | 9.7 | 11 | 12 | 13 | 2.2 | 2.3 | 2.6 | 2.7 | 3.0 |
| | 0.38 | 1/8 | 17 | 20 | 22 | 26 | 27 | 30 | 4.9 | 5.2 | 5.8 | 6.1 | 6.6 |
| | 0.70 | 3/16 | -- | -- | -- | -- | -- | -- | 9.1 | 9.5 | 10 | 11 | 12 |
| 270AX | 0.80 | 13/64 | 35 | 42 | 46 | 54 | 56 | 63 | 10 | 11 | 12 | 13 | 14 |
| 270AY | 1.20 | 3/8 | 54 | 63 | 70 | 82 | 84 | 94 | 15 | 16 | 18 | 20 | 21 |

* Calculated for operation with saturated liquid at the valve inlet. To develop these capacities, the pressure drop across the valve must be greater than one-half the inlet Absolute pressure. When liquid is subcooled, valve capacity will increase.

** Valve capacities at 20 to 25 PSIG inlet pressures are approximately 50% of the 80 PSIG ratings.

*** Add suffix 'F' when ordering a valve for use with halocarbon refrigerant.

R12 and R502 capacities are approximately 0.68 x R22 capacities.

270A VALVE & CHAMBER DIMENSIONS

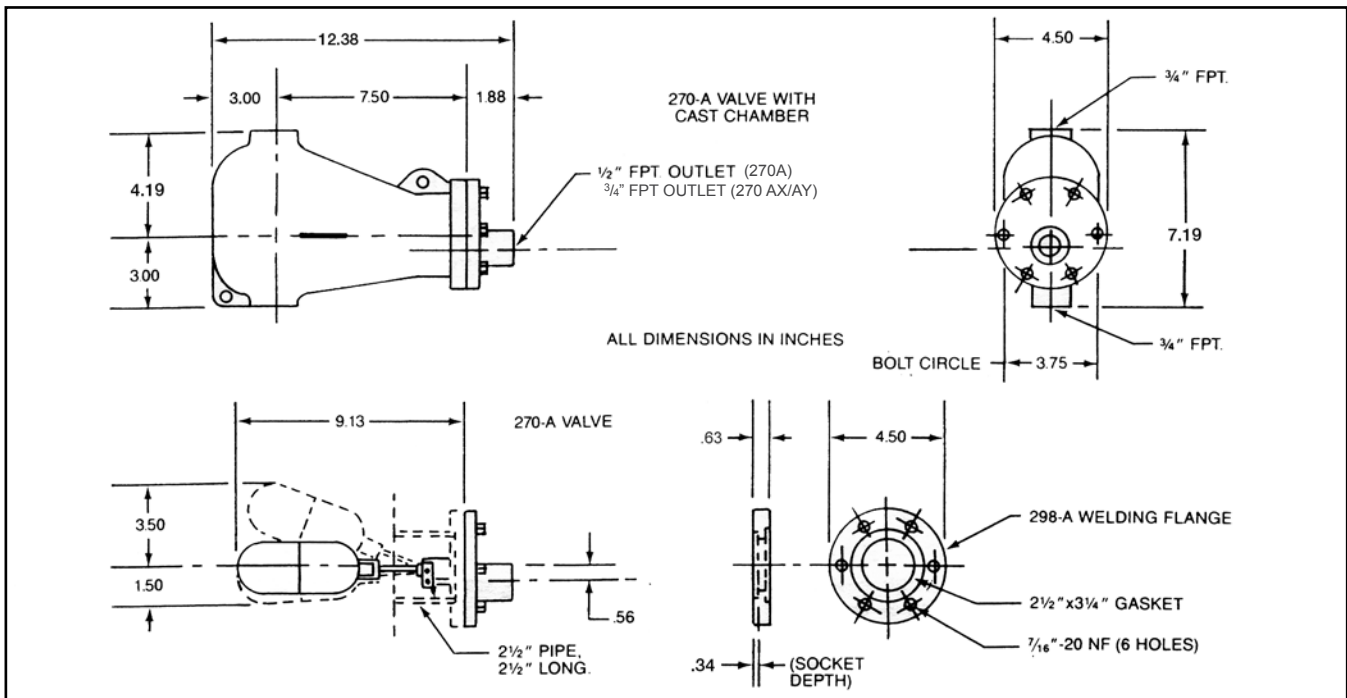

H. A. Phillips & Co.

1612 Louise Drive
 South Elgin, IL 60177-2242 U.S.A.
 Phone: (630) 377-0050 • Fax: (630) 377-2706
 E-mail: info@haphillips.com
 or visit us @ www.haphillips.com

