

Size: 1/2" - 10"

For Ammonia (R-717) and Halocarbon Refrigerants

Features

- A105 Steel
- Designed for 300 PSI, -50°F to +400°F(‡)
- Tongue & Groove
- Available with Threaded, Socket Weld, Weld Neck, and ODC/ODS Connections



FLANGE AND UNION PART NUMBERS

| STYLE OF FLANGE | NOM. PIPE SIZE | FLANGE PART NUMBERS (M=MALE, F=FEMALE) | | | UNION PART NUMBERS | | |
|-----------------|----------------|--|--------------|--------------|--------------------|----------|-----------|
| | | SOCKET | THREADED | WELD NECK | SOCKET | THREADED | WELD NECK |
| OVAL 2-BOLT | 1/2 | 4-MS, 4-FS | 4-MT, 4-FT | N/A | U-4S | U-4T | N/A |
| | 3/4 | 6-MS, 6-FS | 6-MT, 6-FT | N/A | U-6S | U-6T | N/A |
| | 1 | 8-MSO, 8-FSO | 8-MTO, 8-FTO | N/A | U-8SO | U-8TO | N/A |
| SQUARE 4-BOLT | 1 | 8-MS, 8-FS | 8-MT, 8-FT | N/A | U-8S | U-8T | N/A |
| | 1-1/4 | 10-MS, 10-FS | 10-MT, 10-FT | 10-MW, 10-FW | U-10S | U-10T | U-10W |
| | 1-1/2 | 12-MS, 12-FS | 12-MT, 12-FT | 12-MW, 12-FW | U-12S | U-12T | U-12W |
| | 2 | 16-MS, 16-FS | 16-MT, 16-FT | 16-MW, 16-FW | U-16S | U-16T | U-16W |
| | 2-1/2 | 20-MS, 20-FS | N/A | 20-MW, 20-FW | U-20S | N/A | U-20W |
| | 3 | 24-MS, 24-FS | N/A | 24-MW, 24-FW | U-24S | N/A | U-24W |
| ROUND 8-BOLT | 4 | 32-MS, 32-FS | N/A | 32-MW, 32-FW | U-32S | N/A | U-32W |
| | 5 | 40-MS, 40-FS | N/A | 40-MW, 40-FW | U-40S | N/A | U-40W |
| | 5‡ | 40MSY | N/A | 40MWY | N/A | N/A | N/A |
| | 6 | 48-MS, 48-FS | N/A | 48-MW, 48-FW | U-48S | N/A | U-48W |
| | 6‡ | 48MSY | N/A | 48MWY | N/A | N/A | N/A |
| 12-BOLT | 8‡ | 64-MS, 64-FS | N/A | 64-MW, 64-FW | U-64S | N/A | U-64W |
| | 10‡ | 80-MS, 80-FS | N/A | 80-MW, 80-FW | U-80S | N/A | U-80W |

* Flanges machined to York flange dimensions.

‡ These flanges rated for 300PSI, -45°F to +400°F.

FLANGE DIMENSIONS – SOCKET WELD FLANGES

| STYLE OF FLANGE | NOM. PIPE SIZE | A FLANGE DIMENSION | B BOLT CENTERS | C FLANGE WIDTH | D | | | G DEPTH OF SOCKET | BOLTS SIZE | WT. OF FLANGE (LBS.) | WT. OF UNION (LBS.) |
|-----------------|----------------|--------------------------|----------------------|----------------------|-----------------|-------|---------|-------------------------|---------------|----------------------------|---------------------------|
| | | | | | TONGUE & GROOVE | | | | | | |
| | | | | | I.D. | O.D. | DEPTH** | | | | |
| OVAL 2-BOLT | 1/2 | 4-3/8 | 3 | 15/16 | 1-1/4 | 1-7/8 | 1/8 | 7/16 | 5/8 | 1 | 3 |
| | 3/4 | 4-3/8 | 3 | 15/16 | 1-1/4 | 1-7/8 | 1/8 | 1/2 | 5/8 | 1 | 3 |
| | 1 | 4-3/8 | 3 | 15/16 | 1-3/8 | 1-7/8 | 1/8 | 1/2 | 5/8 | 1 | 3 |

| | | | | | | | | | | | |
|------------------|-------|-------|--------|--------|-------|-------|-------|--------|-----|-------|--------|
| SQUARE 4-BOLT | 1 | 3-1/2 | 2-3/8 | 1-1/16 | 1-3/4 | 2-3/8 | 1/8 | 9/16 | 1/2 | 2 | 5 |
| | 1-1/4 | 3-1/2 | 2-3/8 | 1-1/16 | 1-3/4 | 2-3/8 | 1/8 | 9/16 | 1/2 | 1-3/4 | 4-1/2 |
| | 1-1/2 | 4 | 2-3/4 | 1-1/8 | 2 | 2-3/4 | 1/8 | 5/8 | 1/2 | 2-1/4 | 5-1/2 |
| | 2 | 4-1/2 | 3-1/16 | 1-1/8 | 2-1/2 | 3-1/4 | 1/8 | 5/8 | 5/8 | 2-1/2 | 7 |
| | 2-1/2 | 5-1/2 | 3-7/8 | 1-1/2 | 3 | 3-3/4 | 1/8 | 1 | 3/4 | 5 | 12-1/2 |
| | 3 | 6 | 4-1/8 | 1-9/16 | 3-5/8 | 4-3/8 | 1/8 | 1-1/16 | 3/4 | 6 | 15 |
| 4 | 7 | 5 | 1-7/8 | 4-3/4 | 5-1/2 | 1/8 | 1-3/8 | 7/8 | 9 | 22 | |

| | | | | | | | | | | | |
|-----------------|----|--------|--------|---------|--------|--------|------|--------|-----|----|-----|
| ROUND 8-BOLT | 5 | 10-1/4 | 8-1/2 | 1-3/4 | 6-1/8 | 7-1/4 | 1/8 | 1-1/4 | 3/4 | 20 | 47 |
| | 5* | 10-1/4 | 8-1/2 | 1-3/4 | 5-3/4 | 6-1/2 | 1/8 | 1-1/4 | 3/4 | 20 | N/A |
| | 6 | 11-1/4 | 9-1/2 | 1-13/16 | 7-1/8 | 8-1/4 | 1/8 | 1-5/16 | 3/4 | 24 | 55 |
| | 6* | 12-1/4 | 9-3/4 | 1-13/16 | 7 | 7-3/4 | 1/8 | 1-5/16 | 3/4 | 24 | N/A |
| | 8 | 14-1/4 | 12 | 2 | 9-3/8 | 10-1/2 | 3/16 | 1-1/2 | 7/8 | 40 | 90 |
| 12-BOLT | 10 | 16-1/2 | 14-3/8 | 2-1/4 | 11-3/8 | 12-5/8 | 3/16 | 1-3/4 | 7/8 | 60 | 135 |

All dimensions in Inches (nominal dimensions).

*Flanges machined to York flange dimensions.

**Tongue dimension is 1/32" greater than groove dimension.

Oval

Square

Round

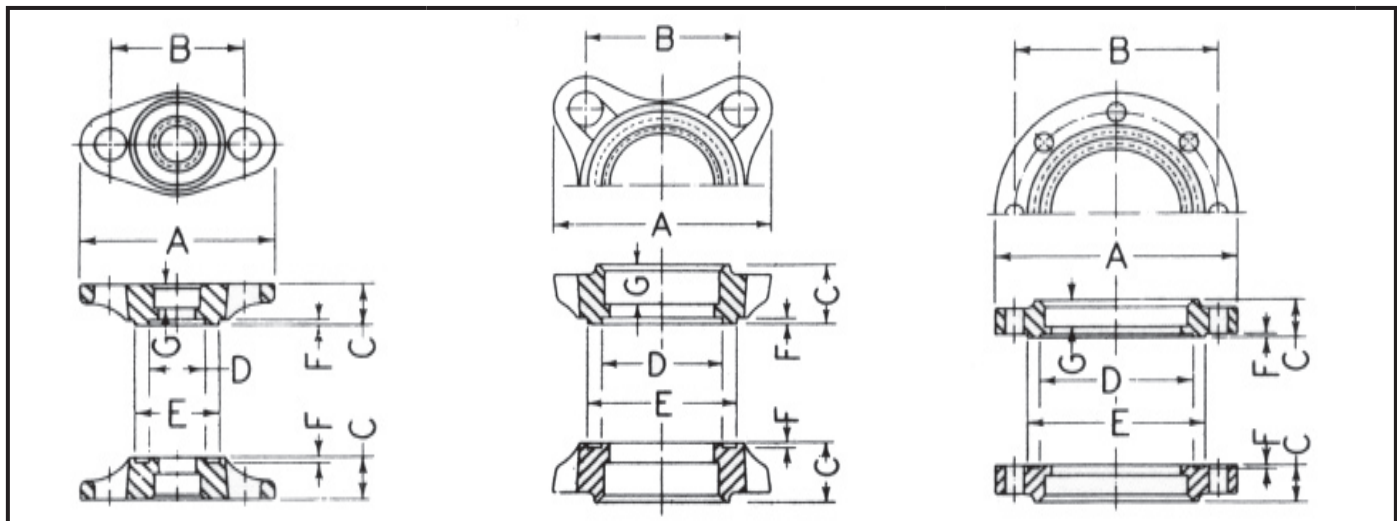

SPARE PARTS

| FLANGE SIZES | 1/2 & 3/4 | 1 Oval | 1 & 1-1/4 | 1-1/2 | 2 | 2-1/2 | 3 | 4 | 5 | 6 | 8 |
|--------------|-----------|--------|-----------|-------|----|-------|------|-------|-----|-----|-----|
| GASKETS | 728 | 626 | 63 | 63W | 73 | 74 | 326Y | 326YA | 5G | 6G | 8G |
| NUTS | 58 | 58 | 57 | 57 | 58 | 59 | 59 | 60 | 59 | 59 | 60 |
| BOLTS | 72 | 72 | 721B | 721B | 72 | 24A | 24A | 24D | 24A | 24A | 24E |

All flange sizes in inches.

H. A. Phillips & Co.

1612 Louise Drive
 South Elgin, IL 60177-2242 U.S.A.
 Phone: (630) 377-0050 • Fax: (630) 377-2706
 E-mail: info@haphillips.com
 or visit us @ www.haphillips.com

